

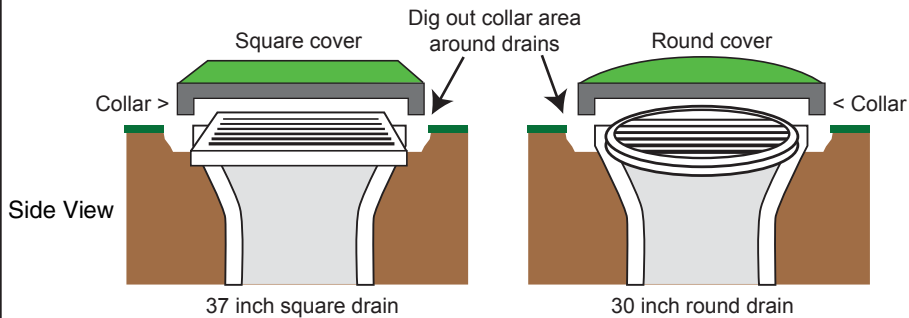

## Installing our Drain Covers

### Square Drain Cover PART NO. 37SG

### Round Drain Cover PART NO. 30-RG



Side View

Top View

Drain Cover

Backfill area in white when finished

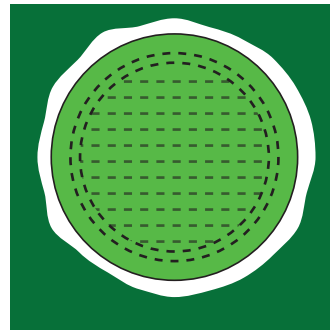
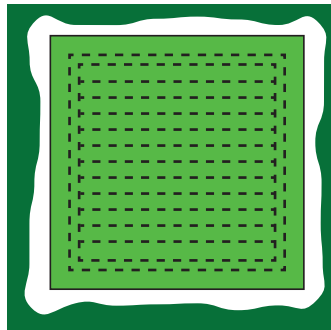

## Easy Installation for Baseball Foundation Mats PART NO. 3240-BBF (Sold in pairs)

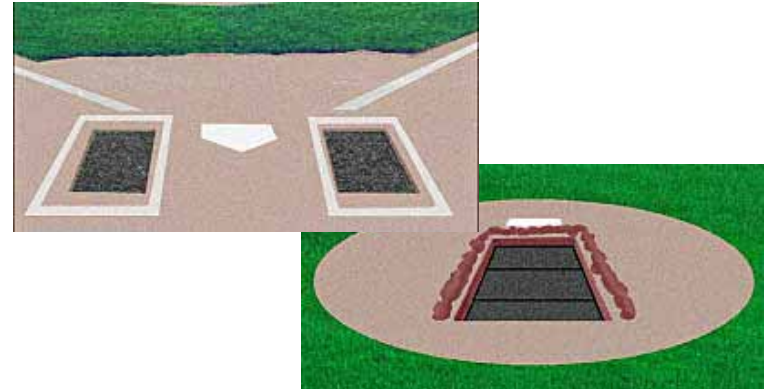

1. Place mats at desired locations
2. Score an area approximately 3-4 inches larger than mat.
3. Remove mats and dig approximately 3-4 inches deep.  
See 3a below to improve drainage **EVEN MORE**
4. Re-insert mat, backfill with surface dirt & tamp area.
5. You're ready to play!

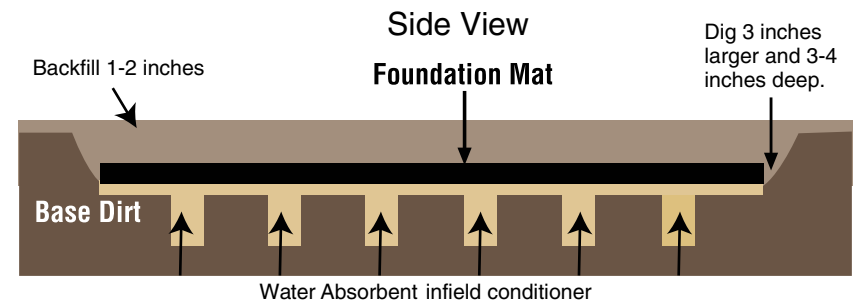

### 3a - Tip from the Pros to improve drainage **EVEN MORE:**

Before installing foundation mats, use a bulb auger (try our **GSA-12**), drill a few drain holes - approx. 1" dia. x 10" deep

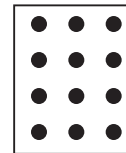

Fill holes and 1" of the excavated areas with **water absorbent infield conditioner**